

TYPICAL WIRING DIAGRAM

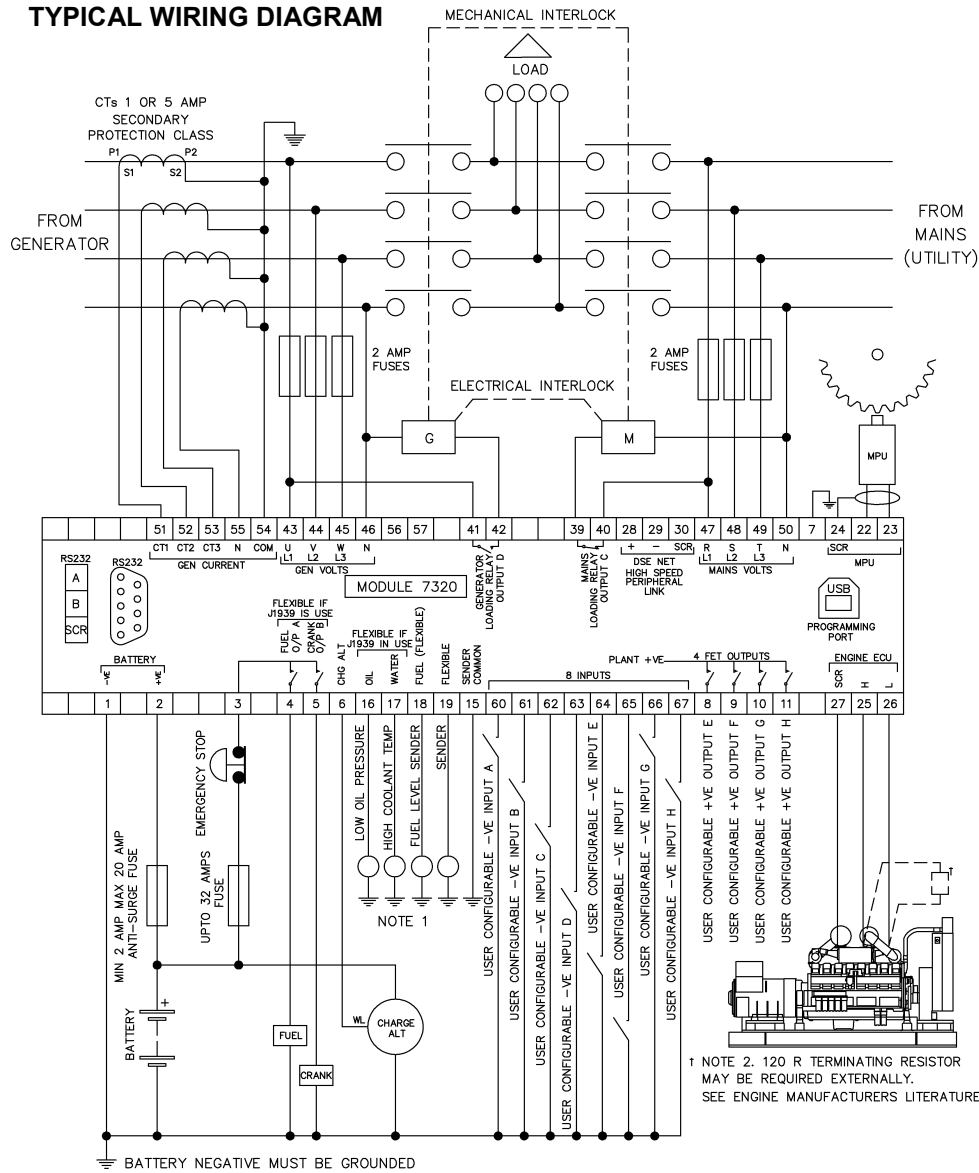

TERMINALS SUITABLE FOR 22-16 AWG (0.6mm - 1.3mm) FIELD WIRING TIGHTENING TORQUE = 0.8Nm (7lb-in)

NOTE 1
THESE GROUND CONNECTIONS MUST BE ON THE ENGINE BLOCK, AND MUST BE TO THE SENDER BODIES.

THE GROUND WIRE TO TERMINAL 15 MUST NOT BE USED TO PROVIDE A GROUND CONNECTION TO ANY OTHER DEVICE



ACCESSING THE FRONT PANEL CONFIGURATION EDITOR

- Ensure the engine is at rest and the module is in STOP mode by pressing the Stop/Reset button.
- Press the Stop/Reset and Info buttons simultaneously.
- If a module security PIN has been set, the PIN number request is then shown :

Editor
 Enter Pin
 ###
- Press the first '#' changes to '0'. Press (up) or (down) to adjust it to the correct value.
- Press (right) when the first digit is correctly entered. The digit you have just entered will now show '#' for security.
- Repeat this process for the other digits of the PIN number. You can press (left) if you need to move back to adjust one of the previous digits.
- When is pressed after editing the final PIN digit, the PIN is checked for validity. If the number is not correct, you must re-enter the PIN.
- If the PIN has been successfully entered (or the module PIN has not been enabled), the editor is displayed :

Editor - Display
 Contrast
 53%

EDITING A PARAMETER

- Enter the editor as described above.
- Press the left or right buttons to cycle to the section you wish to view/change.
- Press the up or down buttons to select the parameter you wish to view/change within the currently selected section.
- To edit the parameter, press to enter edit mode. The parameter begins to flash to indicate that you are editing the value.
- Press the up or down buttons to change the parameter to the required value.
- Press to save the value. The parameter ceases flashing to indicate that it has been saved.
- To exit the editor at any time, press and hold the button.

NOTE 2: 120 R TERMINATING RESISTOR MAY BE REQUIRED EXTERNALLY. SEE ENGINE MANUFACTURERS LITERATURE

Deep Sea Electronics Plc.

Tel: +44 (0)1723 890099
 Fax: +44 (0)1723 893303
 LO CALL (from UK BT landlines):
 Telephone 0845 260 8933
 Email: support@deepseapl.com
 Web: www.deepseapl.com

Deep Sea Electronics inc.

Phone: +1 (815) 316-8706
 Fax: +1 (815) 316-8708
 TOLL FREE (USA only): Tel: 1 866 636 9703
 Email: dsesales@deepseausa.com
 Web: www.deepseausa.com

Deep Sea Electronics Plc.

(Far East)
 Tel: +66 2 670 6228
 Fax: +66 2 678 3028
 Email: support@deepseapl.com
 Web: www.deepseapl.com

- NOTE: When the editor is visible, it is automatically exited after 5 minutes of inactivity to ensure security.
- NOTE: The PIN number is automatically reset when the editor is exited (manually or automatically) to ensure security.
- NOTE: More comprehensive module configuration is possible using the 7xxx series PC configuration software. Please contact us for further details

ADJUSTABLE PARAMETERS (Configuration editor)

Front Panel Configuration Editor

Section	Parameter as shown on display	Factory Settings	
DISPLAY	Contrast	53%	
	Language	English	
	LCD Page Timer	5m	
	Auto Scroll Delay	2s	
	Current Date and time	hh:mm	
EDITOR	Alt Config	Default Config	
ENGINE	Oil Pressure Low Shutdown	1.03bar	
	Oil Pressure Low Pre Alarm	1.17bar	
	Coolant Temperature Low Warning	70°C	
	Coolant Temperature High Pre Alarm	90°C	
	Coolant Temperature High Shutdown	95°C	
	Start Delay Timer	5s	
	Pre Heat Timer	0s	
	Crank Duration Timer	10s	
	Crank Rest Timer	10s	
	Safety On Delay	10s	
	Smoke Limiting	0s	
	Smoke Limiting Off	0s	
	warm Up Timer	0s	
	Cool Down Timer	1m	
	Engine Under Speed Shutdown	Inactive	
	Engine Under Speed Shutdown	1200RPM	
	Engine Under Speed warning	Inactive	
	Engine Under Speed warning	1350RPM	
	Engine Over Speed warning	Inactive	
	Engine Over Speed warning	1650RPM	
	Engine Over Speed Shutdown	1710RPM	
	Engine Speed Overshoot Delay	2s	
	Engine Speed Overshoot	0s	
	Fail To Stop Delay	30s	
	Battery Under voltage warning	Active	
	Battery Under voltage warning Delay	1m	
	Battery Under voltage	10V	
	Battery Over voltage warning	Active	
	Battery Over voltage warning Delay	1m	
	Battery Over voltage warning	30V	
	Charge Alternator Failure warning	Active	
	Charge Alternator Failure warning	6V	
	Charge Alternator warning Delay	5s	
	Charge Alternator Failure Shutdown	Active	
	Charge Alternator Failure Shutdown	4.0V	
	Charge Alternator Shutdown Delay	5s	
	Droop control	Inactive	
	Droop control	4% (Compatible engine ECUs only)	
	GENERATOR	Generator Under Voltage Shutdown	184V
		Generator Under Voltage Pre Alarm	196V
		Generator Voltage Nominal	230V
		Generator Over Voltage Pre Alarm	265V
		Generator Over Voltage Shutdown	277V
		Generator Under Frequency Shutdown	40Hz
		Generator Under Frequency Pre Alarm	42Hz
		Generator Frequency Nominal	50Hz
		Generator Over Frequency Pre Alarm	55Hz
Generator Over Frequency Shutdown		57Hz	
Full Load Rating		500A	
Kw Overload Trip		100%	
Delayed Over Current		Active	
Delayed Over Current		100%	
AC System		3 Phase, 4 wire	
CT Primary		600A	
CT Secondary		5A	
Earth CT Primary		500A	
Earth Fault Trip		Inactive	
Earth Fault Trip		10%	
Generator Transient Delay	0s		



Front Panel Configuration Editor

Section	Parameter as shown on display	Factory Settings	
MAINS	Mains Under voltage Trip	184V	
	Mains Over voltage Trip	276V	
	Mains Under Frequency Trip	45Hz	
	Mains Over Frequency Trip	55Hz	
	Mains Transient Delay	2s	
	Return Delay	30s	
	Mains Transfer Time	0.7s	
	TIMERS	LCD Page Timer	5m
		Auto Scroll Delay	3s
		Start Delay Timer	5s
Pre Heat Timer		0s	
Crank Duration Timer		10s	
Crank Rest Timer		10s	
Safety On Delay		10s	
Smoke Limiting		0s	
Smoke Limiting Off		0s	
warm up Timer		0s	
Cool Down Timer		1m	
Speed Overshoot Delay		2s	
Fail To Stop Delay		30s	
Battery voltage Low warning Delay		1m	
Battery voltage High warning Delay		1m	
Return Delay		30s	
Generator Transient Delay		0s	
Mains Transient Delay	2s		
Mains Transfer Time	0.7s		

ACCESSING THE 'RUNNING' CONFIGURATION EDITOR

- The 'running' editor can be entered while the engine is running. All protections remain active if the engine is running while the running editor is entered.
- Press and hold the  button to enter the running editor.

EDITING A PARAMETER

- Enter the editor as described above.
- Press the left or right buttons to cycle to the section you wish to view/change.
- Press the up or down buttons to select the parameter you wish to view/change within the currently selected section.
- To edit the parameter, press  to enter edit mode. The parameter begins to flash to indicate that you are editing the value.
- Press the up or down buttons to change the parameter to the required value.
- Press  to save the value. The parameter ceases flashing to indicate that it has been saved.
- To exit the editor at any time, press and hold the  button.

ADJUSTABLE PARAMETERS (Running editor)

Running Editor

Section	Parameter as shown on display	Factory Settings
DISPLAY	Contrast	53%
	Language	English
ENGINE	Manual Frequency Trim (Electronic engines only)	0.0Hz

DIMENSIONS

240.0mm x 181.1mm x 41.7mm (9.4" x 7.1" x 1.6")

PANEL CUTOUT:

220mm x 160mm (8.7" x 6.3")